

Varenummer: 0109065
 Beskrivelse: Seeger låsering AS 48X2.5
 Fjederstål
 Note: Monteres med ZGA tang

Mål

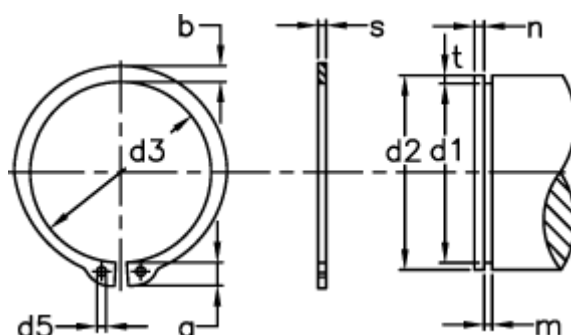

a max	= 7.8	d5 min	= 2.5	s	= 2.50
AN mm ²	= 184.0	FN kN	= 30.70	t	= 1.25
B	= 5.04	FRg kN	= 19.5	Tang	= ZGA-3
b	= 5.0	FR kN	= 101.0	tol	= -0.07
Betegnelse	= AS 48	g	= 2.0	tol	= +0,39 -0,90
d1	= 45.5	m min	= 2.65	tol	= -0.25
d2	= 48	n abl x 1000	= 10	vægt kg/1000	= 12.20
d3	= 44.5	Nominel træk	= 3.8		